

## **SW EW FLUSH GIRT CONDITION**

CA0015 - SW OR EW HOT ROLL FLUSH GIRT DETAIL

CA1001 - FLUSH GIRT BOLT PLACEMENT DETAIL

CA1010 - FLUSH GIRT DETAIL

CA2000 - FLUSH GIRT TO ENDWALL DETAIL

CA2010 - GIRT TO SINGLE CEE RAFTER

CA2020 - GIRT TO DOUBLE CEE RAFTER

---

CA0015 - SW OR EW HOT ROLL FLUSH GIRT DETAIL

[Download the DWG file by clicking here.](#)

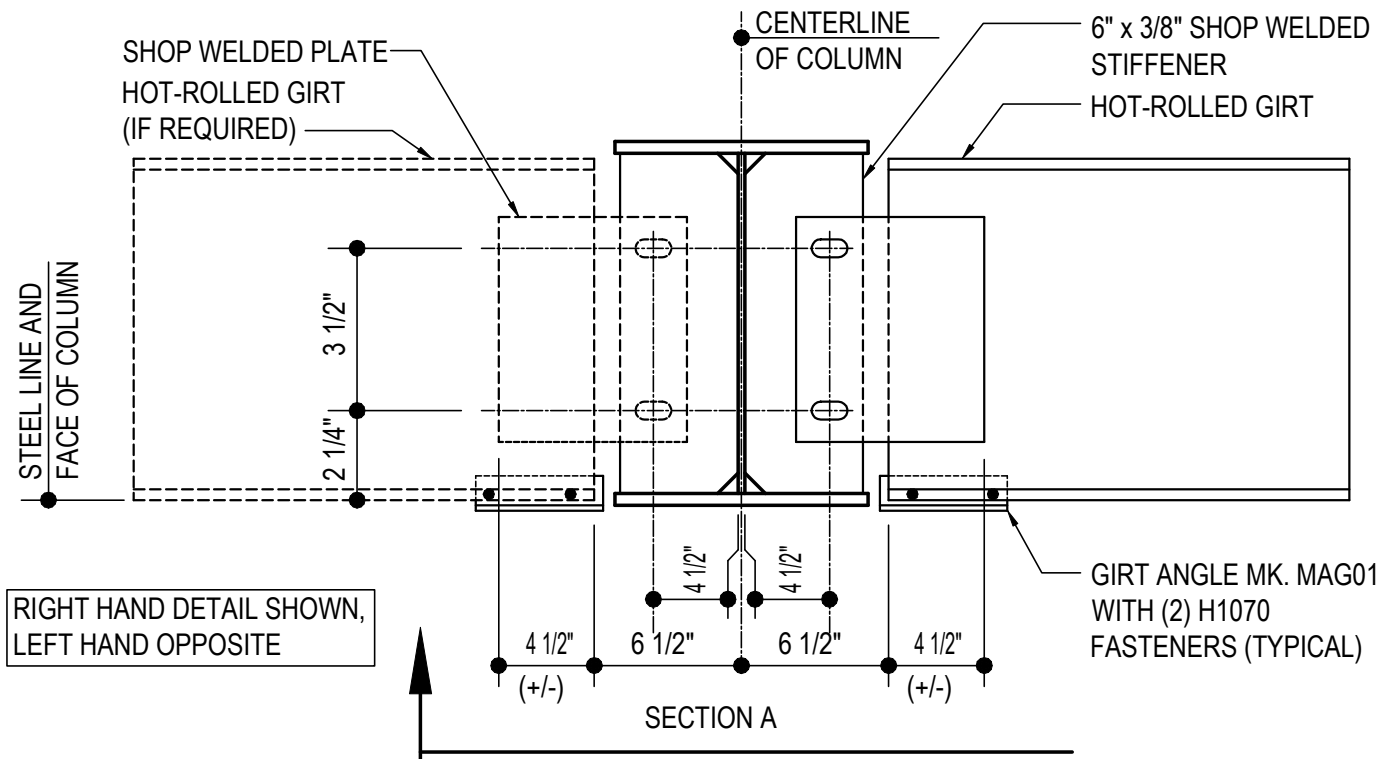
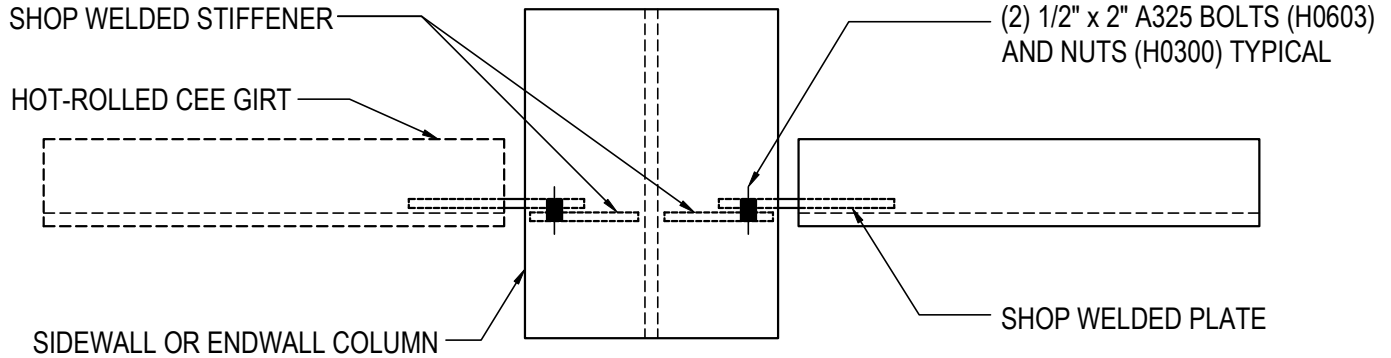

## SW OR EW HOT ROLL GIRT DETAIL

FLUSH GIRTS AT INTERIOR BAY COLUMNS

NOTE: USE (4) 1/2" x 2" A325 BOLTS (MK. H0603) & NUTS (MK. H0300)

REFERENCE ERECTOR NOTE FOR TYPICAL WASHER REQUIREMENTS

**CA0015**

Detailer Notes:

- 1) SHOP WELDED PLATE TO HOT-ROLLED GIRT = GCP06

CA1001 - FLUSH GIRT BOLT PLACEMENT DETAIL

[Download the DWG file by clicking here.](#)

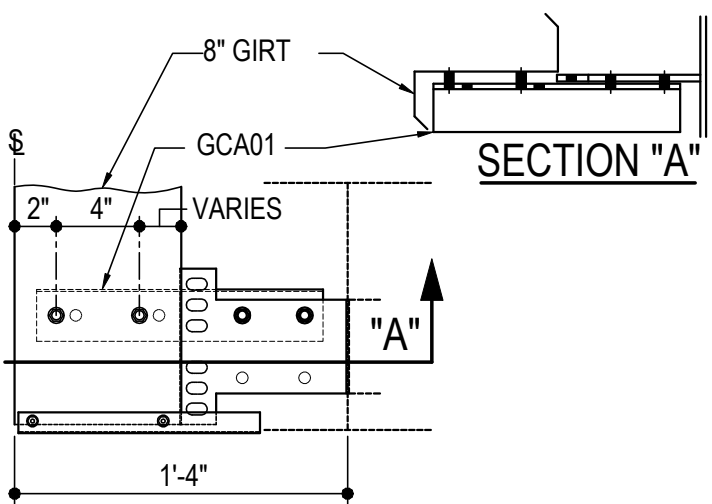

**8" OR 12" GIRT AT CORNER**

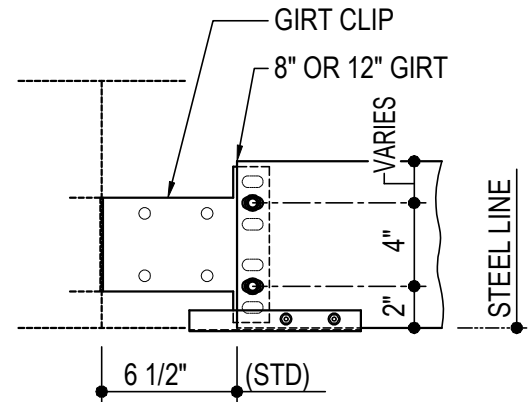

**8" OR 12" GIRT AT SW OR EW**

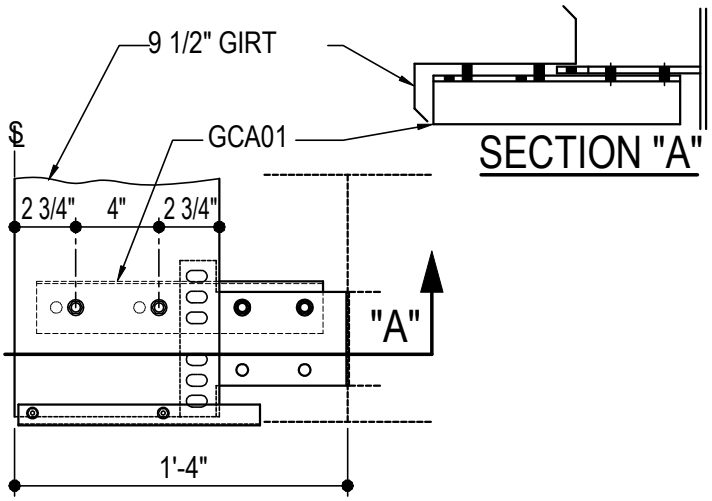

**9 1/2" GIRT AT CORNER**

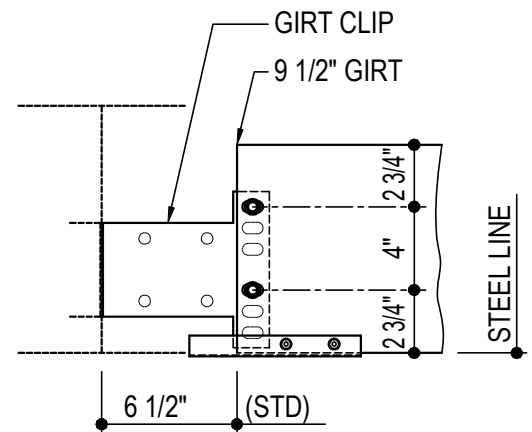

**9 1/2" GIRT AT SW OR EW**

## FLUSH GIRT BOLT PLACEMENT DETAIL

REFERENCE WASHER DETAIL FOR TYPICAL WASHER REQUIREMENTS  
 GIRT CLIPS ARE FACTORY PUNCHED TO BE USED WITH MULTIPLE GIRT DEPTHS.  
 REFER TO THE DETAILS ABOVE TO DETERMINE WHICH HOLES ARE UTILIZED.

**CA1001**

Detailer Notes:

- 1) N/A

CA1010 - FLUSH GIRT DETAIL

[Download the DWG file by clicking here.](#)

## ERECTOR NOTE

GIRT CLIPS ARE FACTORY PUNCHED TO BE USED WITH MULTIPLE GIRT DEPTHS.  
REFER TO THE STANDARD BOLT PLACEMENT DETAIL(S) FOR PROPER BOLT PLACEMENT.

RIGHT HAND DETAIL SHOWN, LEFT HAND OPPOSITE

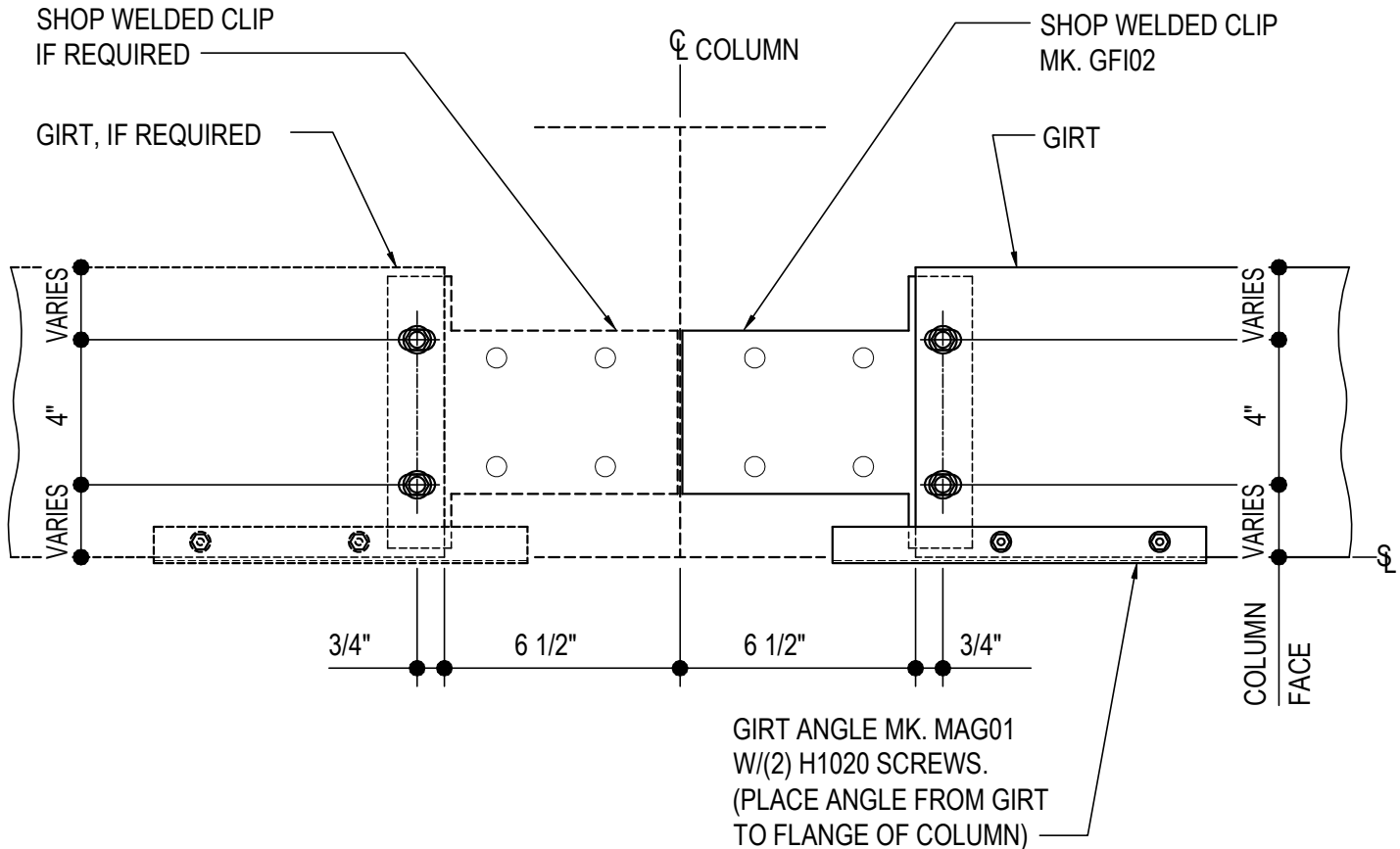

## FLUSH GIRT DETAIL

FLUSH GIRTS AT INTERIOR BAY COLUMNS

NOTE: USE (4) 1/2" x 1 1/4" A307 BOLTS H0500/NUTS H0400

REFERENCE STANDARD WASHER DETAIL FOR TYPICAL WASHER REQUIREMENTS

**CA1010**

Detailer Notes:

- 1) N/A

CA2000 - FLUSH GIRT TO ENDWALL DETAIL

[Download the DWG file by clicking here.](#)

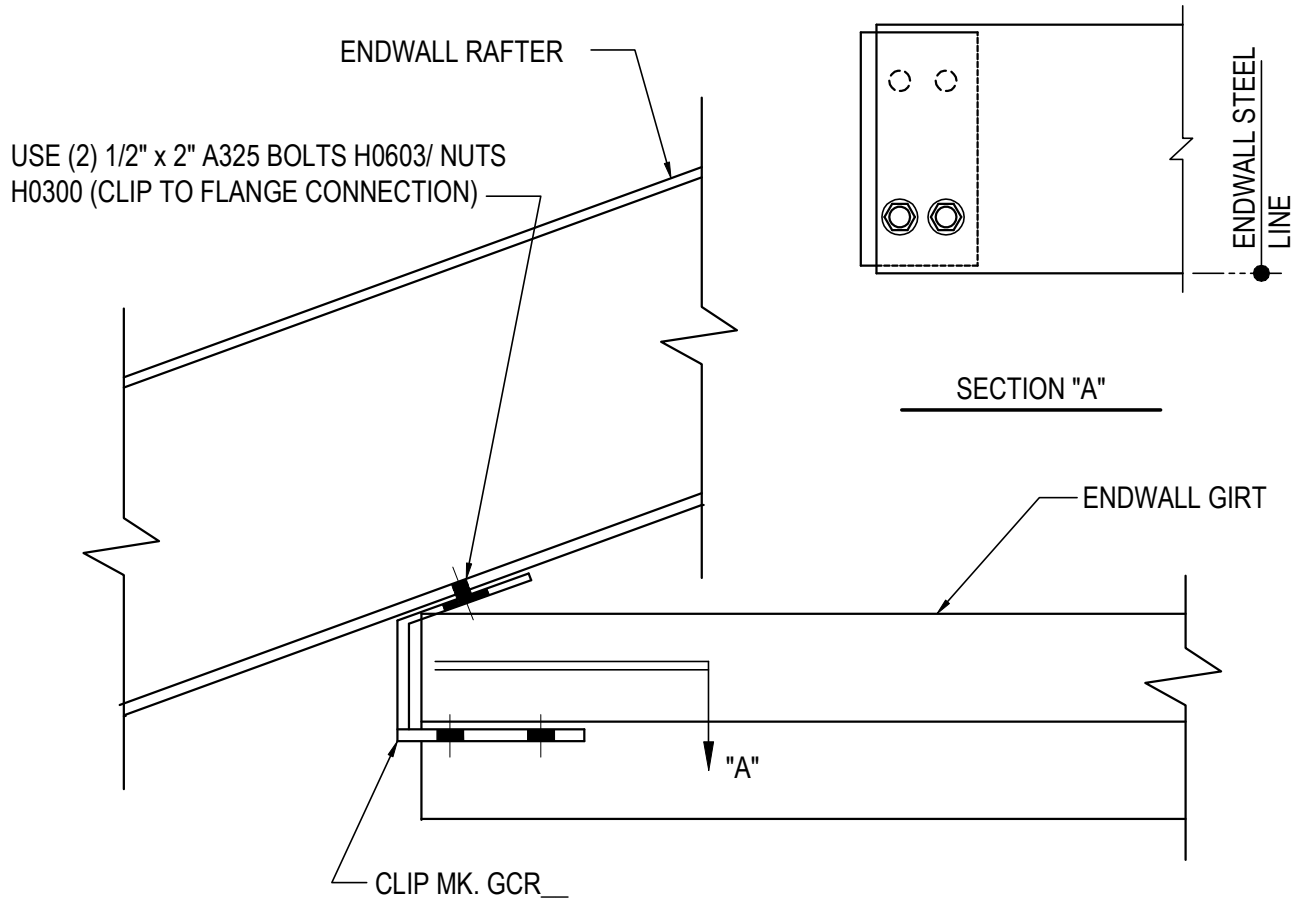

## GIRT TO ENDWALL RAFTER

FLUSH GIRT AT EW RAFTER

(2) 1/2" x 1 1/4" A307 BOLTS H0500/NUTS H0400

REFERENCE ERECTOR NOTE FOR TYPICAL WASHER REQUIREMENTS

**CA2000**

Detailer Notes:

- 1) N/A

## CA2010 - GIRT TO SINGLE CEE RAFTER

[Download the DWG file by clicking here.](#)

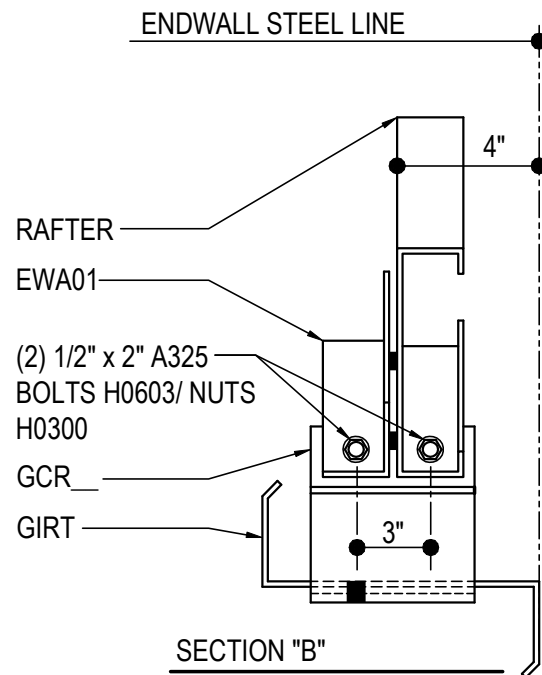
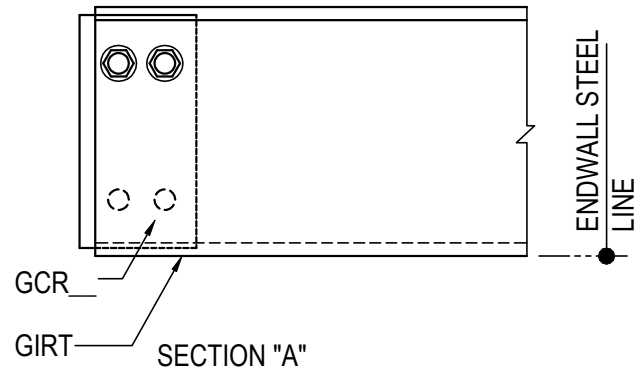
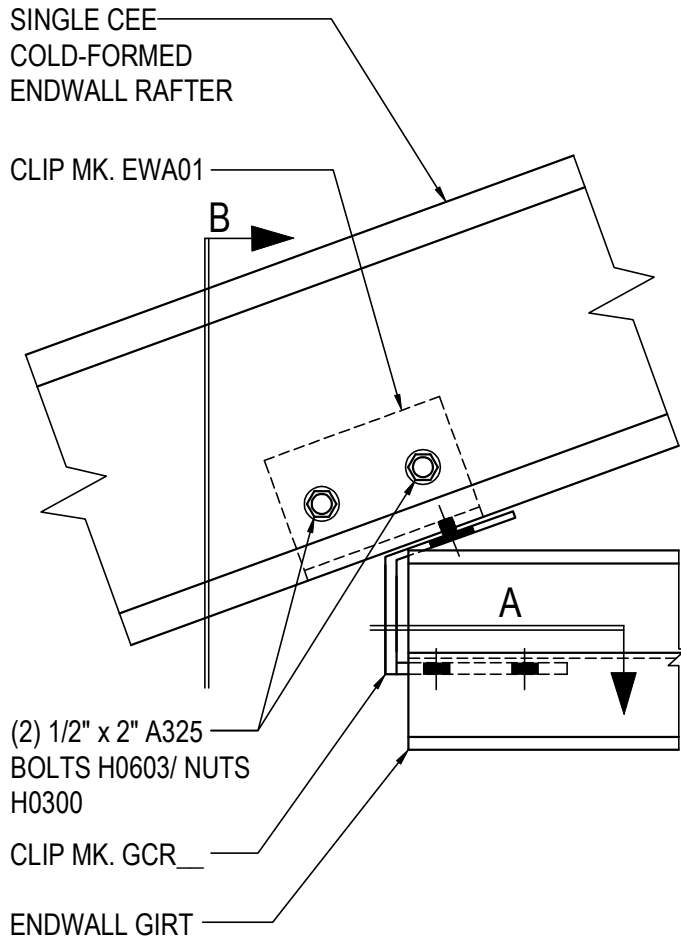

## GIRT TO SINGLE CEE RAFTER

FLUSH ZEE GIRT AT SINGLE CEE COLD-FORMED ENDWALL RAFTER  
(2) 1/2" x 1 1/4" A307 BOLTS H0500/NUTS H0400  
REFERENCE ERECTOR NOTE FOR TYPICAL WASHER REQUIREMENTS

**CA2010**

### Detailer Notes:

- 1) N/A

CA2020 - GIRT TO DOUBLE CEE RAFTER

[Download the DWG file by clicking here.](#)

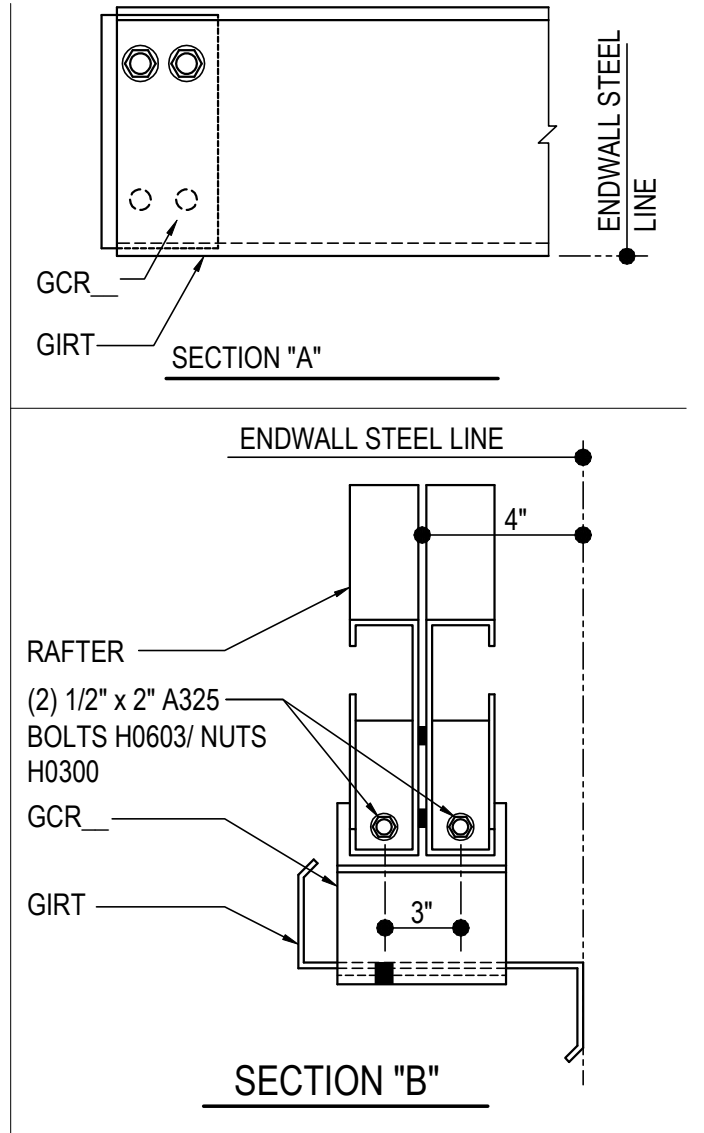
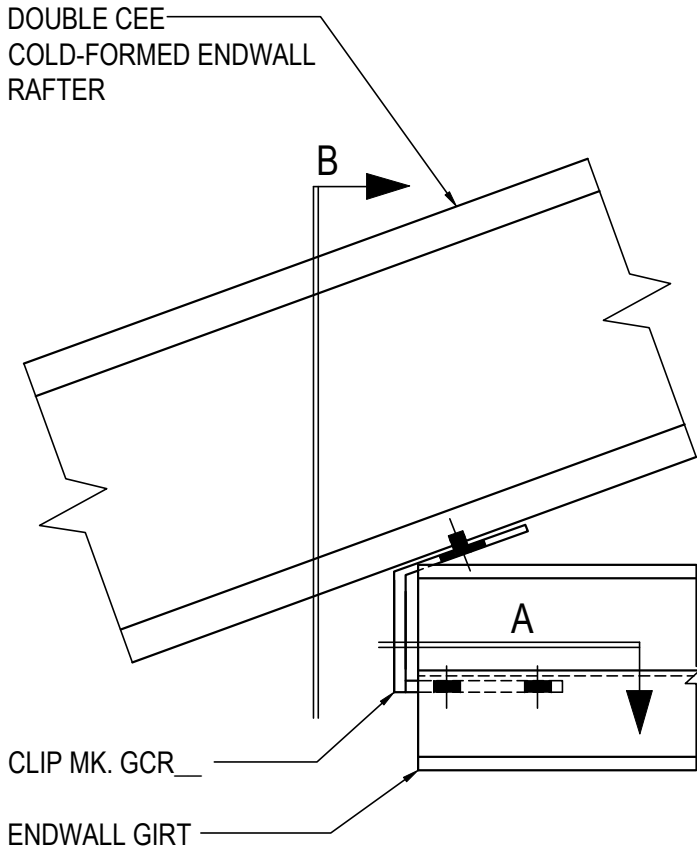

## GIRT TO DOUBLE CEE RAFTER

FLUSH ZEE GIRT AT DOUBLE CEE COLD-FORMED ENDWALL RAFTER  
 (2) 1/2" x 1 1/4" A307 BOLTS H0500/NUTS H0400  
 REFERENCE ERECTOR NOTE FOR TYPICAL WASHER REQUIREMENTS

**CA2020**

Detailer Notes:

- 1) N/A